

ATM-Einführung

ATM und QoS

Autor & Dozent
Dipl.-Inform. Herbert Almus

Einleitung: ATM's Vision

Das Integrierte Dienste-Netzwerk

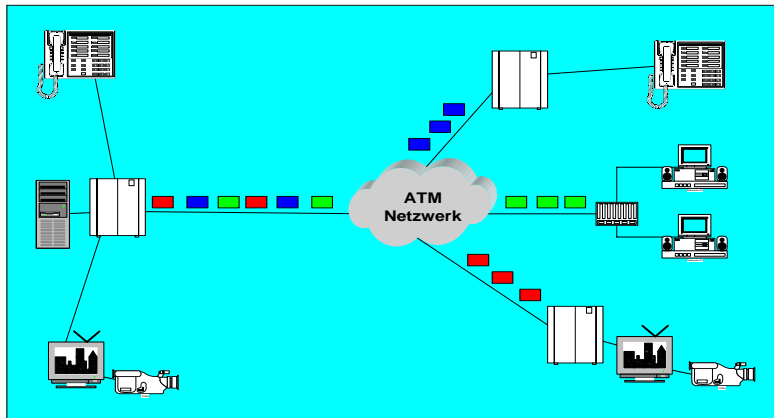

- ATM-Netze übertragen Zellen (Pakete fester Länge mit geringem Delay und Jitter in hoher Geschwindigkeit)
- Endsysteme führen die Umformung (das Segmentieren und Reassemblieren) zwischen den originalen Datenpaketen und Zellen durch

ATM's Konzept

- Kombination von STM (Synchronous Transfer Mode) und PTM (Paket Transfer Mode)

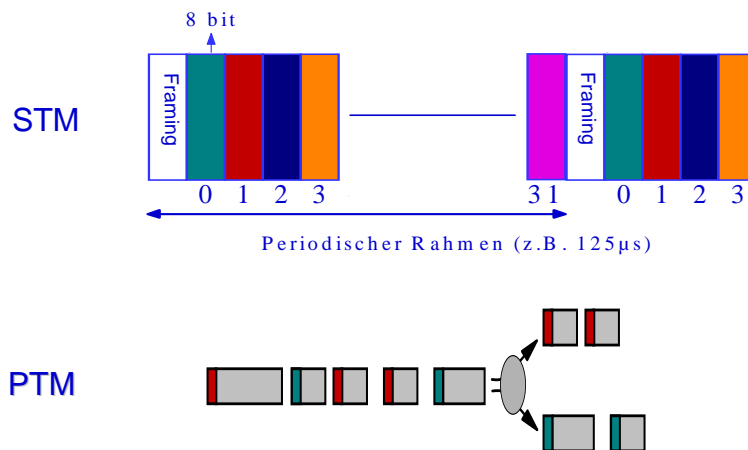

Copyright 2006, Herbert Almus

Seite 3

ATM's Idee: Die Zelle



- Verwendung kleiner Übertragungseinheiten
 - ◆ vereinfacht die Übertragung von Audiodaten (z.B. Telefonie)
 - ◆ Verlust einer einzelnen Zelle bedeutet nur geringen Datenverlust
- Header mit kurzem Verbindungs-Identifizier
 - ◆ Statistisches Multiplexing verschiedener Verbindungen über gemeinsame Übertragungsstrecken.
- ATM-Historie
 - ◆ 1986 als Basis für B-ISDN beschlossen
 - ☞ Entwicklung begann 1988 durch CCITT
 - ◆ ATM Forum (gegründet 1991)
 - ☞ Schwerpunkt: ATM als LAN Technologie

Copyright 2006, Herbert Almus

Seite 4

Interfaces / B-ISDN Konfiguration

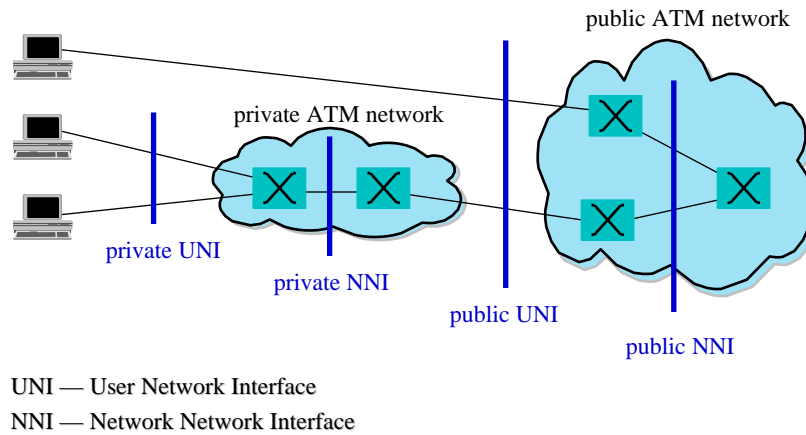

Copyright 2006, Herbert Almus

Seite 5

Standardisierungs-Organisationen

- ITU-T (International Telecommunications Union, Telecommunications Standardization Sector)
- ANSI (American National Standard Institute, Standards für Nord-Amerika)
- ETSI (European Telecommunications Standards Institute, Europäische Standards)
- TTC (Telecommunications Technology Committee, Japanische Standards)
- IETF (Internet Engineering Task Force RFCs betrifft IP über ATM)
- ATM Forum
 - ◆ Spezifikationen für ATM im lokalen / privaten Bereich

Copyright 2006, Herbert Almus

Seite 6

ATM Spezifikationen (Auswahl)

■ ATM Forum

- ◆ UNI 3.0 / 3.1 / 4.0 (User-Network-Interface)
- ◆ ILMI (Integrated Local Management Interface)
- ◆ LAN Emulation V 2.0
- ◆ PNNI V1.0
- ◆ Traffic Management V4.0 / 4.1

■ IETF

- ◆ IP over ATM (RFC 1483 / RFC 1577 / RFC 1755)
- ◆ Default IP MTU for use over ATM AAL5 (RFC 1626)
- ◆ Ipng Support for ATM Services (RFC 1680)
- ◆ IP over ATM: A Framework Document (RFC 1932)

B-ISDN Protocol Reference Model

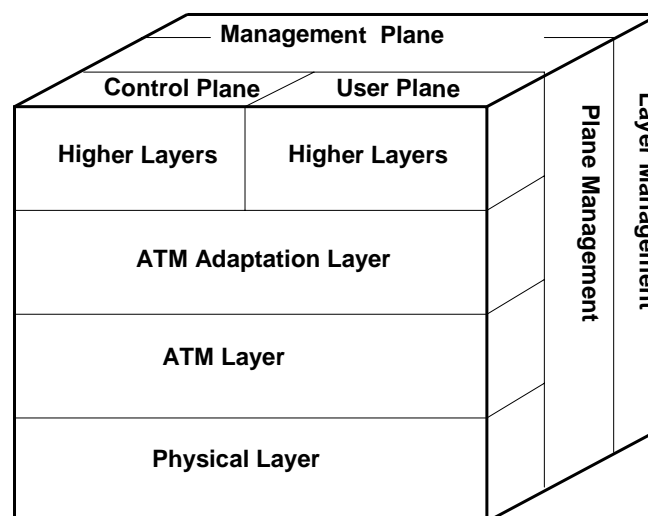

B-ISDN Layers / ATM Layer Model

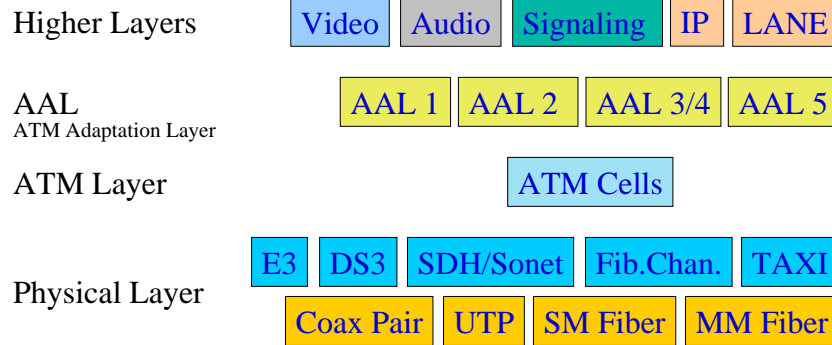

Copyright 2006, Herbert Almus

Seite 9

Higher Layers

- End-to-End Services, Encapsulation, Services Layers
- End-to-End-Services:
 - ◆ Video, Audio, Transport Protocols (TCP/IP, IPX, ...)
- Encapsulation (SNAP, LLC, ...)
- Services
 - ◆ Cell Relay Service, MPEG2, SMDS SIP-3, ILMI, SNMP, Frame Relay, LAN Emulation, ATM Forum UNI / P-NNI, Q.2931, ...

Copyright 2006, Herbert Almus

Seite 10

ATM Adaptation Layer

- assembliert und reassembliert Datenpakete oder Bitfolgen
- definiert verschiedene AAL Protokolle (AAL1, AAL2, AAL3/4, AAL5)
 - ◆ besteht aus einem spezifischen SAR-Sublayer (segmentation and reassembly) und CS-Sublayer (convergence) .
 - ◆ SAR ist zuständig für das Mapping der PDUs (der höheren Layer) in die ATM-Zellen
 - ◆ CS ist dienstespezifisch.
 - ☞ Typische Funktionen: Behandlung von Cell Delay Variation (CDV), clock frequency recovery, transfer of structure information, forward error correction.

ATM Layer

- Multiplexing und Demultiplexing von Zellströme über eine gemeinsame physikalische Leitung
- Generierung bzw. Entfernung der Cell-Header an den Endpunkten der ATM-Verbindungen (ATM-Endsysteme)
- Zuständig für die GFC-Funktion (Generic Flow Control)
 - ◆ existiert nur an der UNI-Schnittstelle
- Umsetzung der ATM-Verbindungsidentifikatoren
- Traffic Management
 - ◆ Sicherstellung der Einhaltung der Übertragungsanforderungen

Physical Layer

- TC-Sublayer (Transmission Convergence)
- PM-Sublayer (Physical Medium)

- TC sublayer
 - ◆ Senden und Empfangen der transmission frames
 - ◆ Cell delineation (Erkennung der cell boundaries)
 - ◆ HEC-Generierung (Header Error Control)
 - ◆ Cell rate decoupling
- PM sublayer
 - ◆ beinhaltet nur die für das physikalische Übertragungsmedium spezifischen Funktionen
 - ◆ realisiert die physikalische Übertragung inkl. Bit Alignment und, falls erforderlich, des Line Coding und der elektrisch-optischen Umsetzung

Copyright 2006, Herbert Almus

Seite 13

Information / Übertragung

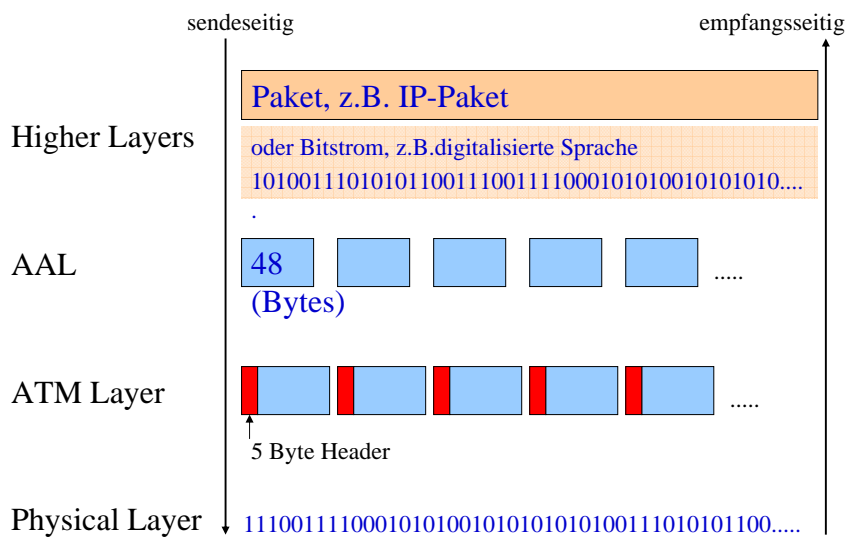

Copyright 2006, Herbert Almus

Seite 14

B-ISDN Planes

- Management Plane
 - ◆ Layer management
 - ☞ Layer-spezifische Aufgaben (z.B. OAM-Datenfluß)
 - ◆ Plane management
 - ☞ Management-Funktionen bezüglich Gesamtsystem
 - ☞ Koordinierung zwischen allen Planes
- User Plane
 - ◆ Übertragung der Benutzerdaten (user data)
 - ◆ erforderliche Mechanismen (flow control, error recovery usw.)
- Control Plane
 - ◆ Verbindungs-Kontrolle (call control)
 - ◆ Kontrolle der Verbindungen (connection control)

Copyright 2006, Herbert Almus

Seite 15

ATM-Layer

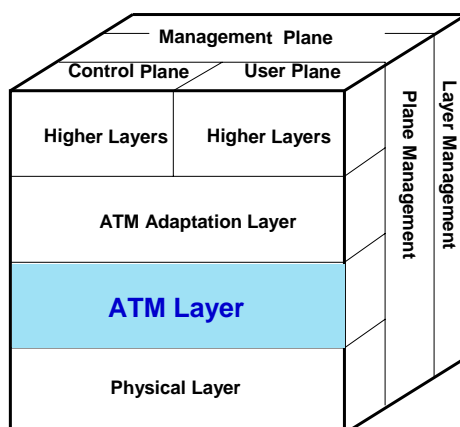

- Transparente Übertragung der Zellen
 - ◆ Anwendungs-unabhängig, für anwendungsspezifische Aspekte ist der AAL zuständig
- Cell (De)Multiplexing
 - ◆ (De)Multiplexing der ATM-Zellen in/aus einem kontinuierlichen Zellstrom
 - ◆ Einfügung von „idle“ oder „unassigned“ cells (cell rate decoupling)
- Bearbeitung des Cell-Headers
 - ◆ Generierung, Modifizierung und Entfernung

Copyright 2006, Herbert Almus

Seite 16

Funktionen des ATM-Layer

- Quality of Service (QoS) Policing für jede Verbindung
 - ◆ QoS wird beim Verbindungsaufbau ausgehandelt
 - ◆ QoS Parameter: peak cell rate, cell delay variation tolerance (CDVT) (optional), sustainable cell rate (optional), burst tolerance (optional)
- Sicherstellung der Einhaltung der QoS-Parameter (Traffic shaping)
 - ◆ Traffic Monitoring, Veranlassung von geeigneten Aktionen bei Überschreitungen (z.B. Verwerfen von Zellen)
- Congestion Control
- Error Management — OAM cells (F4–F5)
- Flow control (GFC) am UNI
- Meta-Signaling

Copyright 2006, Herbert Almus

Seite 17

ATM Zell-Header

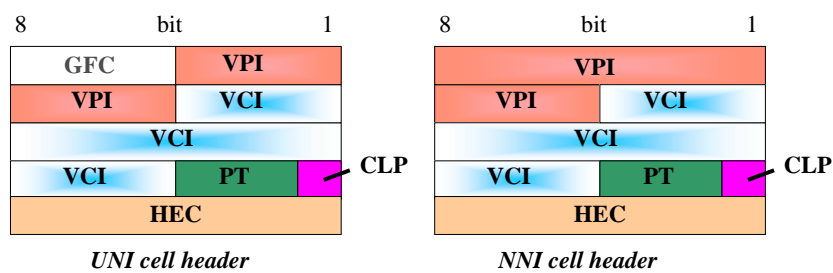

- GFC — generic flow control
- VPI / VCI — virtual path / channel identifier
- PT — payload type
- CLP — cell loss priority
- HEC — header error control

Copyright 2006, Herbert Almus

Seite 18

ATM Zell-Header Aufbau

- GFC — generic flow control
 - ◆ definiert für lokale Datenflußkontrolle
 - ◆ Die Nutzung ist noch nicht spezifiziert (Wert daher immer 0).
- VPI — virtual path identifier
 - ◆ 8 Bit-Feld im UNI-Header, 12 bit im NNI-Header
 - ◆ adressiert den Virtual Path einer ATM-Verbindung; der Default-Wert ist 0. Bei „idle cells“, Meta-Signaling- und OAM-Zellen ist der Wert ebenfalls 0.
- VCI — virtual channel identifier
 - ◆ Dieses Feld (16 Bits) adressiert den Virtual Channel einer ATM-Verbindung; der Default-Wert ist 0. Bei „idle cells“ ist der Wert ebenfalls 0. Ansonsten gibt es vordefinierte Werte für besondere Aufgaben.

ATM Zell-Header Aufbau (2)

Payload Type

000	user data cell, congestion not experienced, SDU-type = 0
001	user data cell, congestion not experienced, SDU-type = 1
010	user data cell, congestion experienced, SDU-type = 0
011	user data cell, congestion experienced, SDU-type = 1
100	Segment OAM F5 flow related cell
101	End-toEnd OAM F5 flow related cell
110	Resource Management Cells for Available Bit Rate (ABR)
111	Reserved for future functions

ATM Zell-Header Aufbau (3)

- CLP — Cell Loss Priority
 - ◆ 3 unterschiedene Situationen: cell passing, cell tagging, cell discarding
 - ◆ Beim Auftreten von Congestion werden Zellen mit low priority (CLP=1) als erste verworfen.
 - ◆ Submitted Loss Priority
 - CLP, mit der die Zelle vom AAL an den ATM-Layer übergeben wird
 - ◆ Received Loss Priority
 - CLP, die der ATM-Layer beim Hochreichen der Zelle an den AAL übergibt.
- HEC — Header Error Control
 - ◆ Das HEC-Byte enthält eine 8-Bit CRC-Checksumme über die ersten 4 Bytes des Headers.

Copyright 2006, Herbert Almus

Seite 21

ATM Verbindungstypen

- virtual channel connections
- virtual path connections
- Verbindungsarten
 - ◆ point-to-point
 - ◆ point-to-multipoint
- Verbindungsaufbauarten
 - ◆ statisch (PVC - permanent virtual circuits)
 - ◆ dynamisch (SVC - switched virtual circuits)

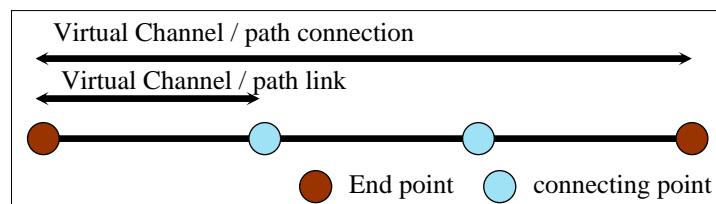

Copyright 2006, Herbert Almus

Seite 22

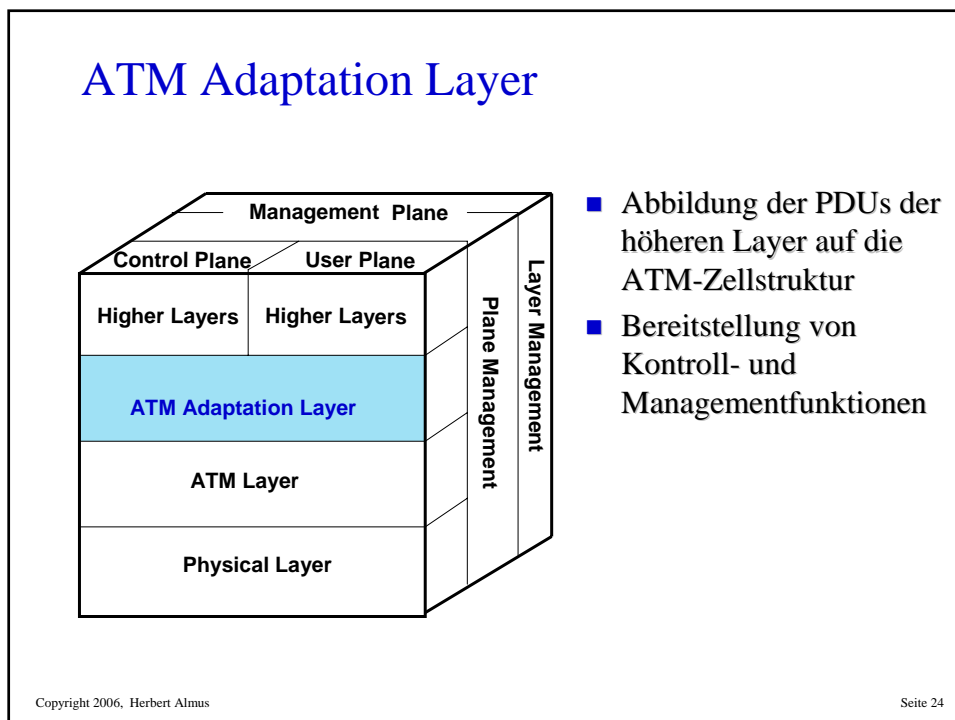
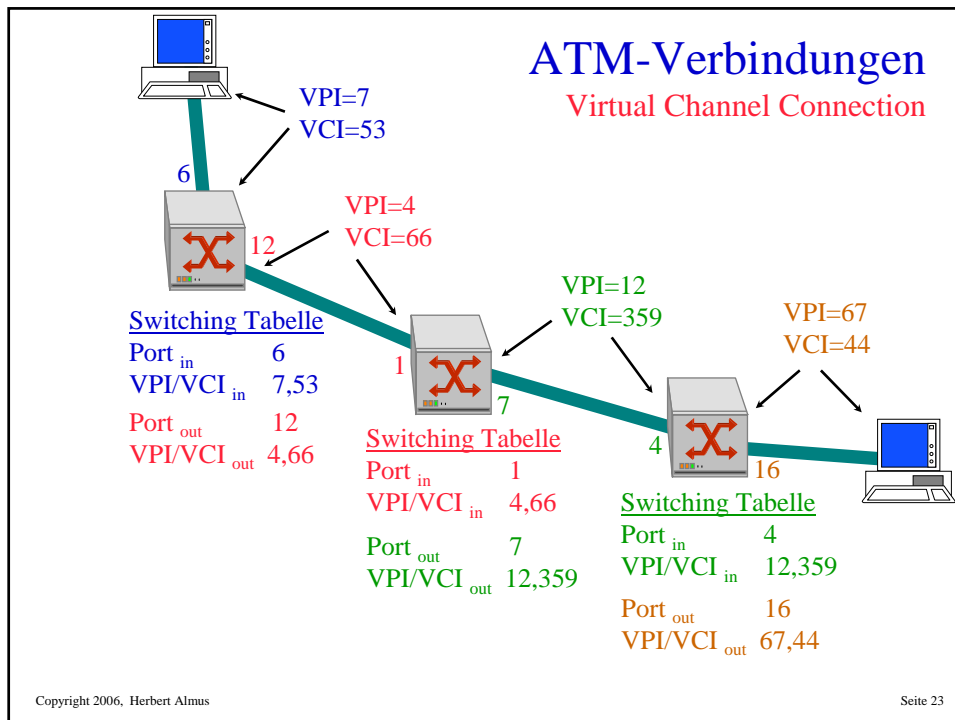

AAL Sublayers

AAL	CS	Convergence Sublayer
	SAR	Segmentation and Reassembling Sublayer

- CS – Convergence Sublayer
 - ◆ Service Specific Convergence Sublayer (SSCS)
 - ☞ dienstespezifischer AAL-SAP
 - ◆ Common Part Convergence Sublayer (CPCS)
- SAR – Segmentation and Reassembly Sublayer
 - ◆ Segmentation und Reassembling des 48-Bytes großen Informationsfelds der ATM-Zelle

AAL Service Classes

Service Classes	Class A	Class B	Class C	Class D
Timing Relation between source and destination	Required		Not required	
Bit rate	Constant	Variable		
Connection mode	Connection-oriented			Conn.-less
Adaptation Type	AAL 1	AAL 2	AAL 3/4 , AAL 5	

- Verbindungsart (connection mode)
 - ◆ Class A: Circuit Emulation; konstante Bitrate, Video
 - ◆ Class B: variable Bitrate , Video und Audio
 - ◆ Class C: verbindungsorientierte Datenübertragung
 - ◆ Class D: verbindungsloser Datentransfer

AAL Typ 1

- verbindungsorientierte Übertragung von
 - ◆ SDUs mit constant bit rate
 - ◆ timing information / structure information
- Funktionen
 - ◆ Segmentation and Reassembly
 - ◆ Bitfehlerüberprüfung
 - ◆ Behandlung von
 - ☞ cell delay variation / cell payload assembly delay
 - ☞ lost and misinserted cells / AAL-PCI bit errors
- Rückgewinnung von
 - ☞ source data structure
 - ☞ source clock frequency

Copyright 2006, Herbert Almus

Seite 27

Unstructured data

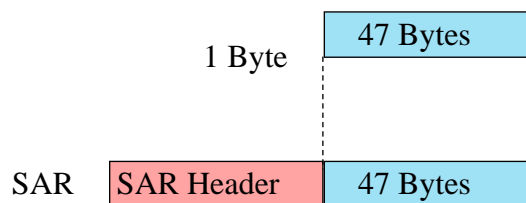

Structured data

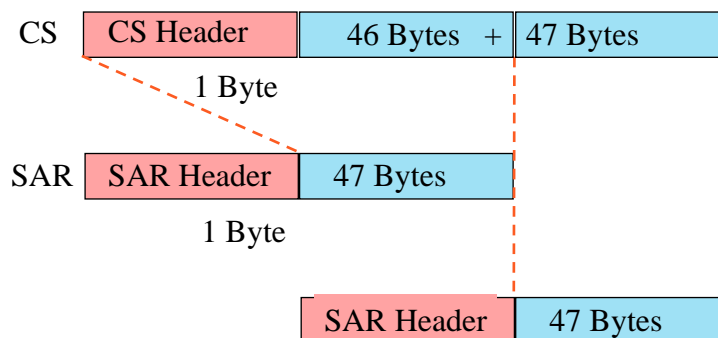

Copyright 2006, Herbert Almus

Seite 28

AAL1 SAR

- 1 Byte SAR Header

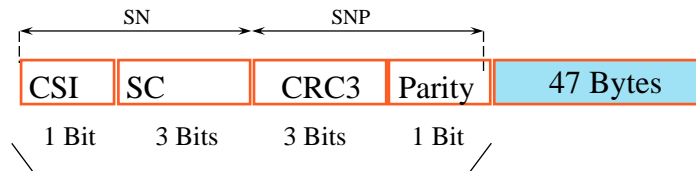

- SN – Sequence Number
 - ◆ CSI – CS Indication – 1 Bit
 - ◆ SC – Sequence Count – 3 Bits
- SNP – SN Protection
 - ◆ single-bit error correction
 - ◆ multiple-bit error detection
 - ◆ CRC – Cyclic Redundancy Check
 - ◆ Parity Bit
 - ☞ SAR führt die Berechnung und Überprüfung des SNP zur Fehlererkennung und -behandlung durch

Copyright 2006, Herbert Almus

Seite 29

AAL 1 CS (1)

- Behandlung von
 - ◆ cell delay variation durch Einsatz eines Buffers (Einfügen von Dummy-Bits oder Entfernen von Bits)
 - ◆ lost and misinserted cells (durch Verarbeitung des sequence count, den der SAR liefert)
- Übertragung der user information
 - ◆ circuit (emulation)
 - ◆ video/voice-band signal
 - ☞ 1 Bit AAL-SDUs für Circuit-Transport
 - ☞ 1 Oktett AAL-SDU für Video/Audio
 - ◆ structured data
 - ☞ Information über den Beginn von Datenblöcken
- forward error correction (FEC)
 - ◆ mittels Reed-Solomon (128,124)-Kodierung

Copyright 2006, Herbert Almus

Seite 30

AAL 1 CS (2)

■ Timing

- ◆ Lieferung der AAL-SDUs mit konstanter Bitrate
- ◆ Source Clock Frequency Recovery:
 - ☞ Synchronous Residual Time Stamp (SRTS) Verfahren
 - Messung und Übertragung der Differenz zwischen der Anwendungsrate (Service-Clock) und der Netzwerkdatenrate (Network-Clock)
 - benutzt das CSI zur Übertragung eines 4-bit RTS
 - ☞ Adaptive Clock Methode
 - Anpassung über Pufferungsverfahren

Kommunikationsaufbau (Beispiel)

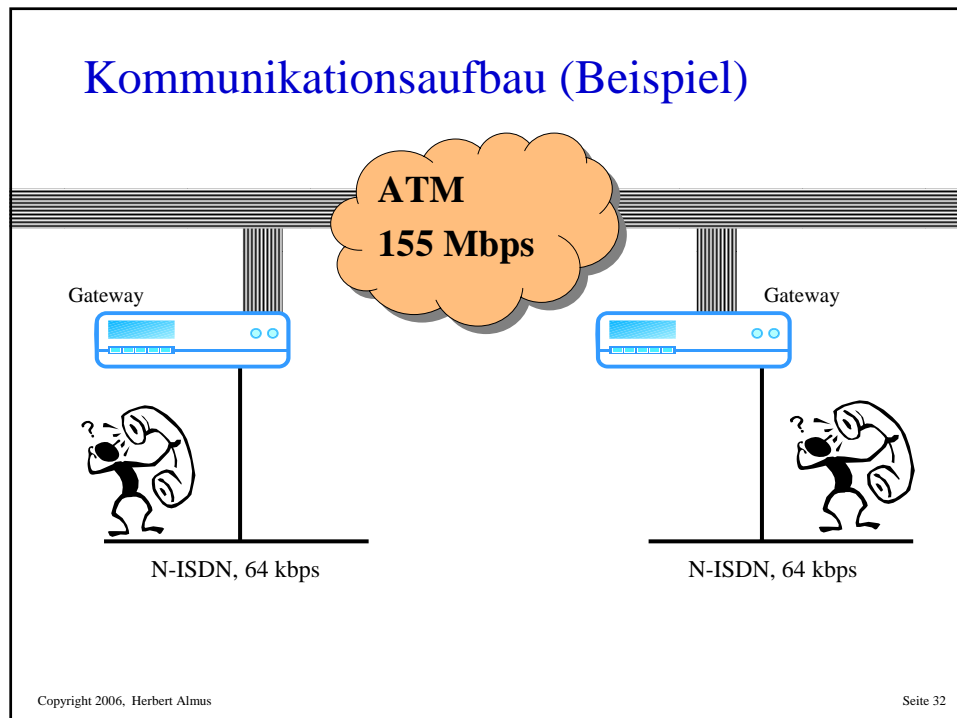

Source Clock Frequency Recovery (1)

Synchronous Residual Time Stamp (SRTS)

fs – service clock
 fn – network clock
 fnx – derived network clock
 N – period of RTS in cycles of the service clock of frequency fs
 T – period of RTS in seconds
 M(Mnom, Mmax, Mmin) – number of fnx cycles within a RTS period
 Mq – largest integer smaller than or equal to M

Copyright 2006, Herbert Almus Seite 33

Source Clock Frequency Recovery (2)

Example: 64 kbit/s ISDN Service

- ISDN service clock frequency: $f_s = 64 \text{ kHz} \pm \Delta f_s$
- period of RTS in cycles of f_s :
 $N = 8 \text{ PDU} \cdot 47 \text{ Byte/PDU} \cdot 8 \text{ bit/Byte} = 3008$
- period of RTS in seconds:
 $T = \frac{N}{f_s} = 47 \text{ ms} \pm \text{tolerance}$
- chosen tolerance of T :
 $\text{max tolerance} = T \cdot \pm 10^{-3} = \pm 47 \mu\text{s}$
- STM-1 common network clock frequency:
 $f_n = 155.52 \text{ MHz}$
- derived network clock frequency:
 $1 < \frac{f_{nx}}{f_s} \leq 2 \Rightarrow f_{nx} = f_n \cdot 2^{-11} = 75.94 \text{ kHz}$
- number of f_{nx} cycles within a RTS period:
 $M_{nom} = \lceil T \cdot f_{nx} \rceil = 3569$
 $M_{min}, M_{max} = M_{nom} \pm \lceil \text{max. tolerance} \cdot f_{nx} \rceil = 3569 \pm 4$

SAR-Header			
CSI	SC	SNP	
X	0	XXXX	
1	1	XXXX	<div style="text-align: right; border: 1px solid black; padding: 2px;">RTS = 1011</div>
X	2	XXXX	
0	3	XXXX	
X	4	XXXX	
1	5	XXXX	
X	6	XXXX	
1	7	XXXX	

Copyright 2006, Herbert Almus Seite 34

Source Clock Frequency Recovery (3)

Adaptive Clock Method

Service Clock des Ziels läuft

... zu langsam

... zu schnell

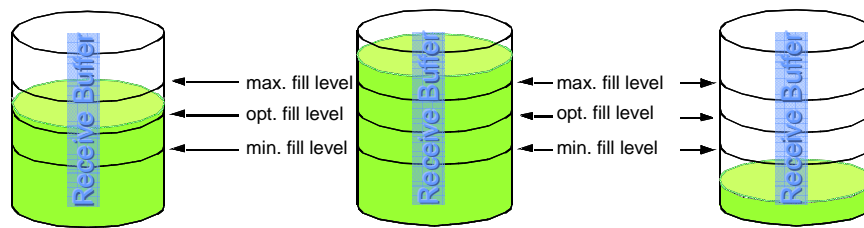

Copyright 2006, Herbert Almus

Seite 35

Übertragung strukturierter Daten

- Beispiele strukturierter Daten:
 - Reed Solomon Code (Forward Error Correction)
 - MPEG Synchronisationsframes

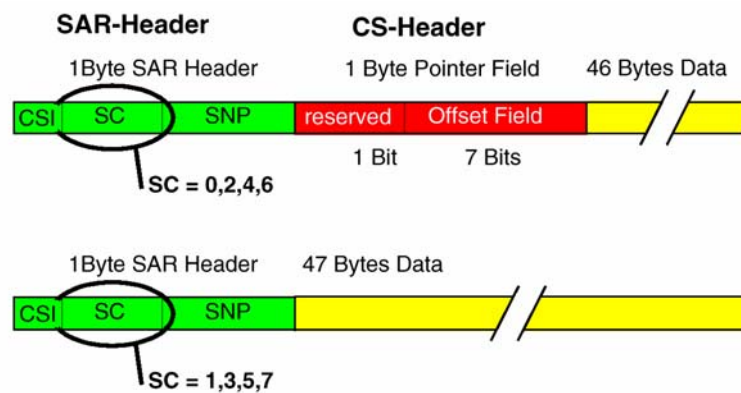

Copyright 2006, Herbert Almus

Seite 36

AAL2 Konzept

- AAL2 bildet ein „Overlay-Netzwerk zum ATM
- **Short Packet Switching** - Netzwerk
 - ◆ verbindungsorientiert, nur Punkt-zu-Punkt-Verbindungen
 - ◆ Paketgröße festgelegt durch **Negotiation Procedure (ANP)**
 - ☞ 64 Byte fest oder 0 .. 45 Byte variable
 - ◆ Definition eines OAM F7 Fluß für
 - ☞ AAL2 Negotiation Procedure
 - ☞ AAL2 Channel Management

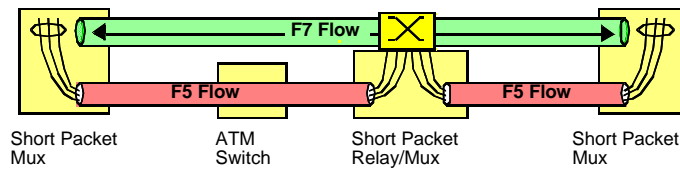

Copyright 2006, Herbert Almus

Seite 39

AAL2 Übertragung

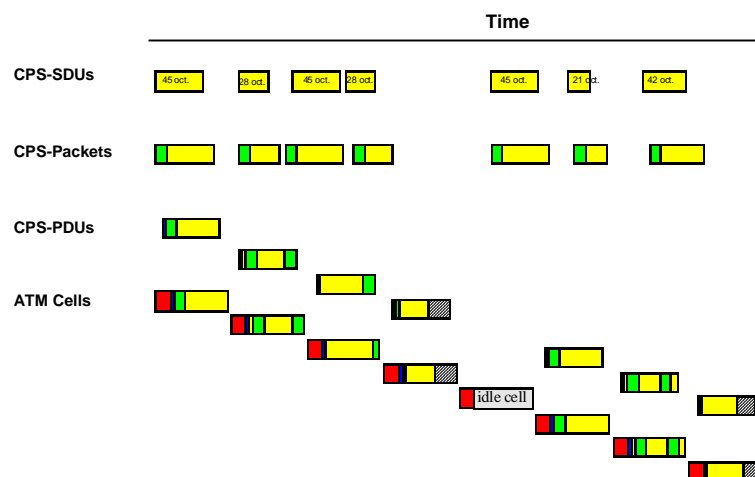

Copyright 2006, Herbert Almus

Seite 40

CPS-Packet Format

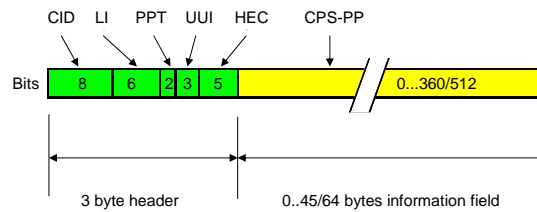

- CPS-PP — CPS Packet Payload
- CID — Channel Identifier
 - ◆ identifiziert den User des AAL2 channel
- LI — Length Indication
 - ◆ Länge der CPS Packet Payload
- PPT — Packet Payload Type
 - ◆ user data, management function
- UII — User-to-User Indication
- HEC — Header Error Control

Copyright 2006, Herbert Almus

Seite 41

CPS-PDU Format

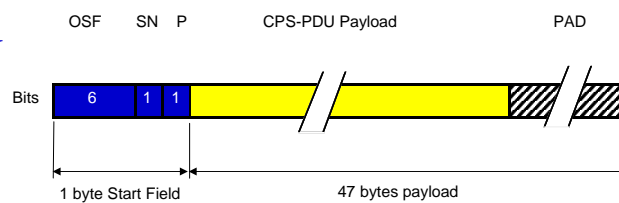

- OSF — Offset Field
 - ◆ offset zwischen Ende des STF und Beginn des ersten CPS-Pakets oder dem Padding
- SN — Sequence Number
- P — Parity
 - ◆ 8 bit parity is odd
- PAD — Padding
 - ◆ Alignment to ATM-SDU

Copyright 2006, Herbert Almus

Seite 42

AAL Typ 3/4

- Message Mode / Streaming Mode
- Garantierte (assured) und nicht garantierte (non-assured) Datenübertragung
- CS unterteilt in Service Specific und Common Part Sublayer
- Point-to-Point und Point-to-Multipoint (ATM layer) Verbindungen (unterstützt durch den CPCS)

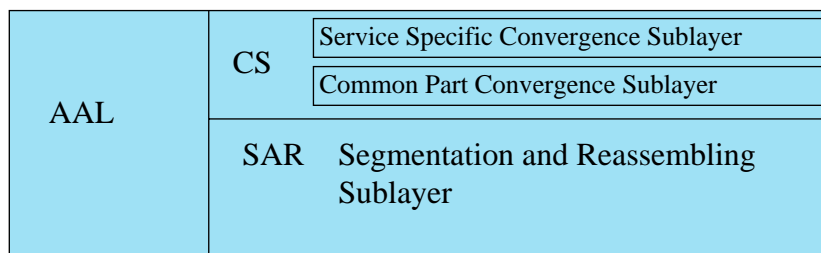

Copyright 2006, Herbert Almus

Seite 43

AAL5

- vereinfachter AAL 3/4
- Message-Mode und Streaming-Mode wie in AAL 3/4
- Übertragungsarten (assured / non-assured data transfer) wie in AAL 3/4
- CS unterteilt in Service Specific und Common Part Sublayer (wie in AAL 3/4)
- Point-to-Point und Point-to-Multipoint (ATM layer) Verbindungen (unterstützt durch den SSCS)

Copyright 2006, Herbert Almus

Seite 44

AAAL5 Überblick

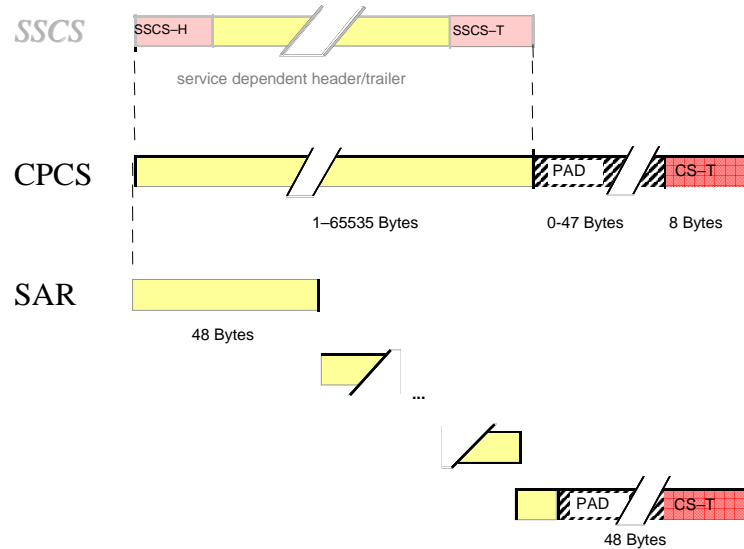

Copyright 2006, Herbert Almus

Seite 45

AAAL5 CS

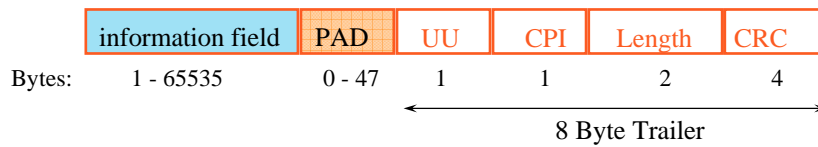

- information field, variable Länge
- PAD - Padding, variable Länge
- UU - CPCS User-to-User Indication
 - ◆ zur Nutzung durch Higher Layers
- CPI - common part indicator
 - ◆ Füll-Byte (kodiert mit 0)
- Length - Länge des information field
- CRC - Cyclic Redundancy Check
 - ◆ über information field, PAD, UU, CPI und Length

Copyright 2006, Herbert Almus

Seite 46

AAL5 CPCS - Funktionen

- Fehlererkennung und Behandlung
 - ◆ Verwerfen der PDU oder Lieferung einer *error indication*
- Behandlung von
 - ◆ congestion information
 - ◆ loss priority information

durch Lieferung der Information an niedrigere / höhere Layer

AAL5 SAR

- SAR-SDU sequence continuity
 - Markierung: begin (0) und end (1) der CPCS-PDU im PT-Feld des ATM-Headers

ATM cell header

GFC	VPI	
VPI	VCI	
VCI		
VPI	PT	CLP
HEC		

Traffic Management



Generelle Zielsetzung

- Realisierung von
 - ◆ Quality of Service (QoS)
 - ◆ Übertragung entsprechend ausgehandeltem Verkehrsvertrag
- Sicherung eines stabilen und zuverlässigen Netzbetriebes
- Behandlung von unerwarteten Netzwerkengpässen
- effiziente, optimale Nutzung von Netzwerk-Ressourcen

- Traffic Management erfolgt auf dem ATM Layer, d.h. nur auf Zell-Ebene

- Standards / Drafts:
 - ◆ ATM Forum UNI 3.1 und Traffic Management 4.0
 - ◆ ITU-T Recommendation I.371

Copyright 2006, Herbert Almus

Seite 49

Elemente des Traffic Management

- Verbindungsaufbau/-abbau
 - ◆ Benutzer wählt Traffic Parameter aus
 - ◆ Connection Admission Control (CAC) überprüft, ob aktuell der Aufbau einer Verbindung mit diesen Parametern möglich ist
- Verbindungs-Phase
 - ◆ Traffic shaping: Benutzer liefert vertragskonformen Datenstrom und setzt / löscht CLP-Bit
 - ◆ Usage Parameter Control (UPC). Netzwerk überprüft Datenstrom auf Einklang mit vereinbarten Verkehrsparametern
 - ◆ Netzwerk markiert / verwirft nicht-konforme Zellen unter Berücksichtigung der Cell Loss Priority
 - ◆ Netzwerk Congestion Control
 - ☞ reduziert den Effekt unerwarteter Engpässe
 - ☞ (optionale) Nutzung der Explicit Forward Congestion Indication

Copyright 2006, Herbert Almus

Seite 50

Traffic Contract

- Ausgehandelt zwischen Benutzer und Netzwerk beim Verbindungsaufbau
- Traffic Contract ist end-to-end-signifikant
- Verbindungsaufbau erfolgt nur bei Einigung
- beinhaltet die ausgehandelten Verkehrsparameter sowie die Quality of Service Class
- beinhaltet implizit
 - ◆ eine Conformance Definition (policing algorithm) und
 - ◆ die Definition der Cell Delay Variation Tolerance (CDVT)

Quality of Service

- definiert auf Basis von End-to-End-Verbindungen,
 - ◆ spezifisch für jeden VPC oder VCC
 - ◆ festgelegt durch QoS-Parameter
 - ☞ cell error ratio, cell loss ratio
 - ☞ cell misinsertion rate
 - ☞ cell delay, mean cell transfer delay, cell delay variation
- QoS Classes (vereinfachte QoS-Klassifizierung)
 - ◆ Class 0 - Unspecified - Best Effort (At Risk)
 - ◆ Class 1 - specified - Circuit Emulation, CBR
 - ◆ Class 2 - specified - VBR Video/Audio
 - ◆ Class 3 - specified - Connection-oriented Data
 - ◆ Class 4 - specified - Connectionless Data
- TM V4.0:
 - ◆ ABR - Available Bit Rate

ATM Layer Service Architektur

Service Category	Example Applications
Constant Bit Rate CBR	Applications sending data streams with constant bit rates: uncompressed videoconferencing ISDN telephony TV programme exchange (studio quality) radio
Real-Time Variable Bit Rate rt-VBR	Applications sending real-time data streams with variable, but well-defined bit rates: compressed videoconferencing (MPEG), remote education and training, compressed telephony, video on demand distribution
Non-Real-Time Variable Bit Rate nrt-VBR	VBR applications without real-time constraints: response time critical transaction processing, e.g. airline reservations, banking transactions
Available Bit Rate ABR (new in UNI4.0)	VBR applications sending data streams with probabilistic (not well-defined) bit rates: high speed interactive service (e.g. CAD/CAM) medical image transfer LAN interconnection remote terminal
Unspecified Bit Rate UBR	Applications without throughput requirements: data file transfer low quality ABR applications

Copyright 2006, Herbert Almus

Seite 53

Zuordnung Attribute zu Service-Kategorien

Attribute		Service Category				
		CBR	rt-VBR	nrt-VBR	ABR	UBR
Traffic Parameters	Peak Cell Rate (PCR) for CLP ^a =0+1	always specified				
	Peak Cell Rate (PCR) for CLP=0	specified if necessary				
	Cell Delay Variation Tolerance (CDVT)	implicitly specified				
	Sustainable Cell Rate (SCR), Maximum Burst Size (MBS)	n/a	specified either for CLP=0+1 or for CLP=0		n/a	
	Minimum Cell Rate (MCR)	n/a			specified	n/a
Quality of Service Parameters	peak-to-peak Cell Delay Variation (CDV)	specified		unspecified		
	mean Cell Transfer Delay (CTD)	unspecified		specified	unspecified	
	maximum CTD	specified		unspecified		
	Cell Loss Ratio (CLR)	specified			specified ^b	unspecified

a.Cell Loss Priority, explained later

b.expect low values for flow-controlled traffic; provision of CLR is network-specific

Copyright 2006, Herbert Almus

Seite 54

Peak Cell Rate

The graph shows bandwidth on the y-axis and time on the x-axis. A red curve represents the bandwidth usage over time. A horizontal line is drawn at the peak of the curve, labeled 'PCR'. Below the x-axis, five intervals are marked with double-headed arrows and labeled T1, T2, T3, T4, and T5. Below these intervals, five points are marked with red text: t0, t1, t2, t3, t4, and t5. Vertical lines connect the T intervals to the t points.

$PCR := 1 / \min \{T_i\}$

In einer UBR-Verbindung wird der Wert zwar gesetzt, hat aber keinerlei Bedeutung!

T_i : inter-arrival time of the requests for all i
t_i : arrival time of a request for sending a cell

Copyright 2006, Herbert Almus Seite 55

Sustainable Cell Rate / Maximum Burst Size

The graph shows bandwidth on the y-axis and time on the x-axis. A red curve represents the bandwidth usage over time. A horizontal dashed line is drawn at a level below the PCR line, labeled 'SCR'. Three yellow brackets are placed under the curve, each labeled 'Burst', indicating periods where the bandwidth usage exceeds the SCR.

- Sustainable Cell Rate (SCR)
 - obere Grenze der durchschnittlichen Zellrate
 - erlaubt *statistisches Multiplexen*
- Maximum Burst Size (MBS)
 - maximale Anzahl aufeinanderfolgender Zellen, die oberhalb der SCR gesendet werden dürfen
 - Generic Cell Rate Algorithm (GCRA) definiert SCR und MBS (formale Definition)
- Burst Tolerance
 - alternative Beschreibung für SCR/MBS

$$BT = \frac{MBS - 1}{\frac{1}{SCR} + \frac{1}{PCR}}$$

Copyright 2006, Herbert Almus Seite 56

Minimum Cell Rate (MCR)

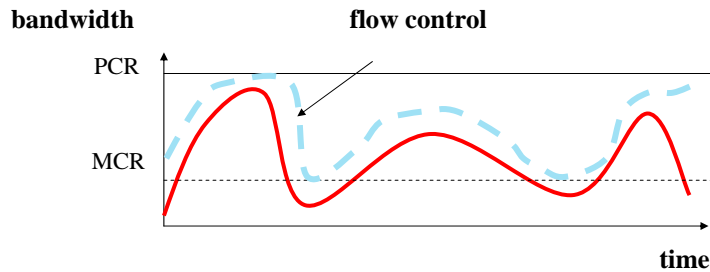

- genutzt bei ABR-Verbindungen
- Netzwerk garantiert MCR
- unterhalb MCR verhält sich die Verbindung wie CBR
- MCR ist immer kleiner gleich PCR, $MCR = 0$ ist zulässig
- Netzbetreiber können MCR begrenzen auf $PCR - \epsilon$

Copyright 2006, Herbert Almus

Seite 57

Quality of Service Parameter

- Cell Loss Ratio
 - ◆ $CLR = \text{Lost Cells} / \text{Transmitted Cells}$
- Mean Cell Transfer Delay (mean CDT)
 - ◆ arithmetisches Mittel der Zeit zwischen Zellversand (source) und Zelleingang (destination)
- Maximum Cell Transfer Delay (max CTD)
- Peak-to-Peak Cell Delay Variation

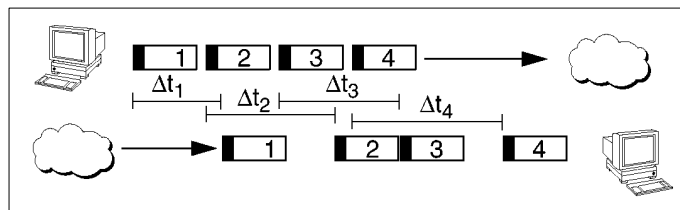

Copyright 2006, Herbert Almus

Seite 58

Traffic Shaping

Beispiel

- 2 Anwendungen

Multiplexed data (without shaper)

Shaped data

Copyright 2006, Herbert Almus Seite 59

Beispiel: CDVT

Legend:

- Δ : cell duration (time for sending 53 bytes)
- T: nominal interarrival time of a request for sending an ATM cell according to PCR
- $ta(i)$: arrival time
- TAT(i): theoretical arrival time $\star ta(i-1) + T$

Copyright 2006, Herbert Almus Seite 60

TM4.0 ABR Resource Management

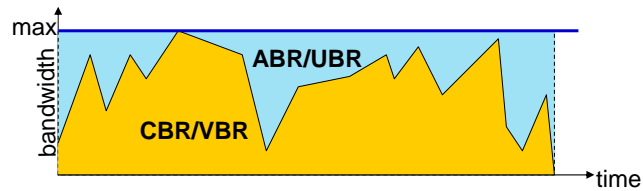

- Ziel
 - ◆ schneller Zugriff auf aktuell ungenutzte Bandbreite
 - ◆ Verbesserung der Ausnutzung des Netzwerk in Umgebungen, in denen VBR (statistisches Multi'plexing) eingesetzt wird
 - ◆ Realisierung einer besseren QoS als sie UBR liefert
 - ☞ Ziel: Minimierung der Zellverluste

Copyright 2006, Herbert Almus

Seite 61

Open vs. Closed Loop

CBR, VBR, UBR: Open Loop

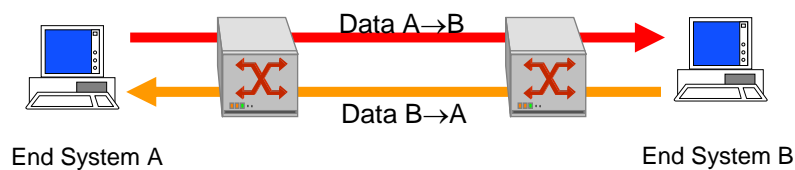

- Kein Feedback
 - ◆ keine Information über Netzengpässe
- Ressourcen-Reservierung zur Zeit des Verbindungsaufbaus
 - ◆ Reservierung von mehr Bandbreite als erforderlich (over-allocation)

Copyright 2006, Herbert Almus

Seite 62

Open vs. Closed Loop

ABR: Closed Loop

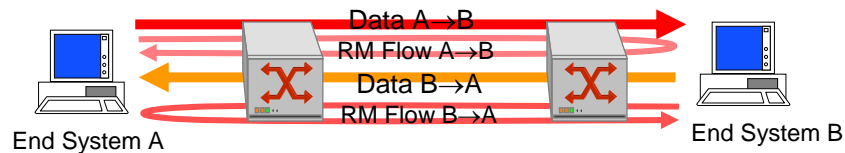

- Resource Management (RM) Cell Flows

- ◆ Mitteilung der verfügbaren Bandbreite an den Sender
- ◆ RM Cell Flow erfolgt parallel zum Datenfluß
- ◆ Ein RM Cell Flow pro unidirektionalen Datenfluß erforderlich

Copyright 2006, Herbert Almus

Seite 63

Resource Management Cell

- ◆ RM-Zellen sind durch den anderen Payload Type Indicator eindeutig erkennbar
- ◆ RM-Zellen werden alle n Daten-Zellen eingefügt

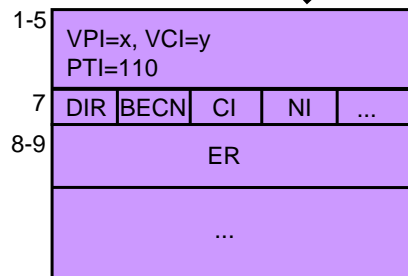
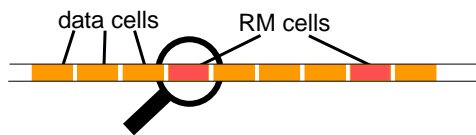

- ◆ DIR: Cell Direction forward/backward
- ◆ BECN: Backward Explicit Congestion Notification
- ◆ CI: Congestion Indicator
- ◆ NI: No Source Rate Increase
- ◆ ER: Explicit Cell Rate

Copyright 2006, Herbert Almus

Seite 64

EFCI Flow Control

Explicit Forward Congestion Indication

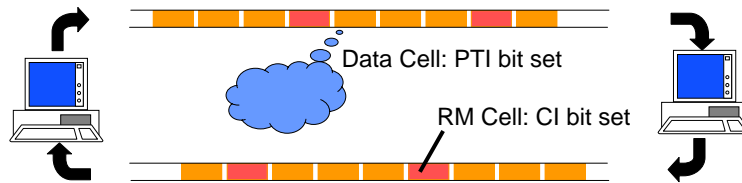

- ◆ Switche kennen kein ABR, setzen nur PTI Congestion Bit
- ◆ Ziel liest PTI congestion bit aus den User-Datenfluß
- ◆ Ziel sendet RM-Zellen mit Congestion Indication (CI) Bit gesetzt, wenn Zellen mit gesetztem PTI Congestion Bit eintreffen
- ◆ Quelle empfängt RM-Zellen und adaptiert entsprechend die Senderate
- ◆ Vorteil: einfach, keine Unterstützung in den Switches erforderlich
- ◆ Nachteil: hohe Latenzzeit, geringe Information (schneller / langsamer)

Copyright 2006, Herbert Almus

Seite 65

Relative Rate Flow Control

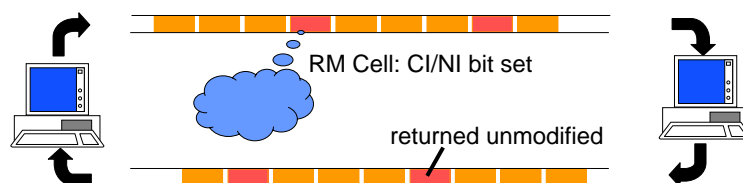

- ◆ Switche setzen Congestion Indication (CI) Bit in RM-Zellen
- ◆ Switches können ebenso No Source Rate Increase (NI) Bit in RM -Zellen setzen
- ◆ Ziel sendet RM-Zellen unmodifiziert zurück
- ◆ Quelle empfängt die RM-Zellen und adaptiert die Übertragungsrate
- ◆ Vorteil: einfach, bessere Performanz als EFCI (early switch action)
- ◆ Nachteil: geringe Information (schneller / langsamer)

Copyright 2006, Herbert Almus

Seite 66

Explicit Rate Flow Control

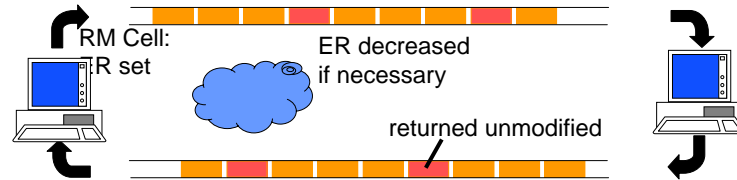

- ◆ Quelle setzt Explicit Cell Rate (ER) auf die gewünschte Bandbreite
- ◆ Switches im Netz reduzieren die ER, falls
- ◆ Ziel sendet RM-Zellen unmodifiziert zurück
- ◆ Quelle adaptiert die Übertragungsrates entsprechend dem empfangenen ER-Wert
- ◆ Vorteil: exakte Information
- ◆ Nachteil: komplex, Switches müssen eine faire Verteilung der Bandbreite unter konkurrierenden ABR-Anforderungen realisieren.

Copyright 2006, Herbert Almus

Seite 67

Minimum Cell Rate (MCR)

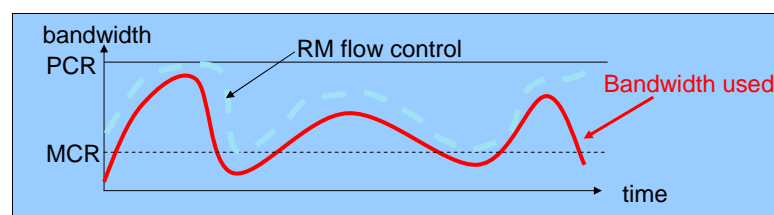

- ◆ Die RM-Flußkontrolle ermittelt nur Werte zwischen **Minimum Cell Rate** und **Peak Cell Rate** ($MCR \leftrightarrow PCR$)
- ◆ Das Netzwerk garantiert, daß mindestens die MCR verfügbar ist.
- ◆ Unterhalb der MCR verhält sich eine ABR-Verbindung wie eine CBR-Verbindung
- ◆ MCR ist maximal identisch mit PCR
- ◆ MCR=0 ist erlaubt

Copyright 2006, Herbert Almus

Seite 68

ABR Parameters

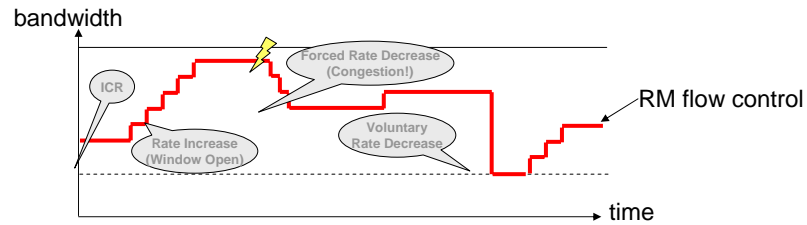

- ◆ ICR (Initial Cell Rate) die anfangs zu nutzende Bandbreite
- ◆ Nrm definiert, nach wie viel Datenzellen eine RM-Zelle gesendet werden darf.
- ◆ Trm definiert den maximalen zeitlichen Abstand zwischen 2 RM -Zellen.
- ◆ RIF (Rate Increase Factor) definiert, mit welcher Rate der Sender die Übertragung erhöhen darf bei Empfang einer "good" RM-Zelle
- ◆ RDF (Rate Decrease Factor) definiert, mit welcher Rate der Sender die Übertragung zu verringern hat bei Empfang einer "bad" RM-Zelle.

Copyright 2006, Herbert Almus

Seite 69

Frame Discard



Konventionelles Vorgehen: Zellen werden bei Überlast statistisch verteilt verworfen (führt im Beispiel zum Verlust von 66 % der Frames)

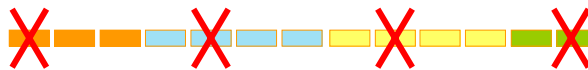

Bessere Methode: statt einzelner Zellen komplette AAL5-Frames zu verwerfen.

Führt in diesem Beispiel zu nur 33 % Frame-Verlust (bei gleicher Zellverlustrate)



Realisierung: Switch kontrolliert PTI-Feld zur Bestimmung der Framegrenzen (SDU-Type = 1 kennzeichnet letzte Zelle eines AAL5-Frames)

Copyright 2006, Herbert Almus

Seite 70

Herzlichen Dank!



Fragen?

Copyright 2006, Herbert Almus

Seite 71

Anhänge

Copyright 2006, Herbert Almus

Seite 72

CES Referenzen

- UNI 3.1, ATM Forum User-Network Interface (UNI) Specification
- af-bici-0013.003, ATM Forum Broadband Inter-carrier Interface (B-ICI) Specification v2.0
- ANSI T1.630-1993, B-ISDN ATM Adaptation Layer CBR Services
- ANSI T1.627-1993, B-ISDN ATM Layer Functionality and Specification
- ITU-T I.356-1993 B-ISDN ATM layer cell transfer performance
- ITU-T I.362-1993 B-ISDN ATM adaptation layer (AAL) functional description
- ITU-T I.363.1 1996, B-ISDN ATM Adaptation Layer (AAL) Specification, Types 1 and 2

- ANSI T1.101-1994, Synchronization Interface Standard
- ANSI T1.102-1993 Revised - Digital Hierarchy - Electrical Interfaces
- ANSI T1.107-1995, Digital Hierarchy - Formats specifications
- ANSI T1.403-1995, Carrier-to-Customer Installation - DS1 Metallic Interface
- ANSI T1.404-1994, Carrier-to-Customer Installation - DS3 Metallic Interface Specification
- ANSI T1.408-1990, Integrated Services Digital Network (ISDN) Primary Rate -- Customer Installation Metallic Interfaces Layer 1 Specification
- ANSI T1.510-1994, Network Performance Parameters for Dedicated Digital Services - Specifications.

Copyright 2006, Herbert Almus

Seite 73

CES Referenzen (2)

- ITU-T G.824-1993, The control of jitter and wander within digital networks which are based on the 1544 kbit/s digital hierarchy
- Bellcore TR-NWT-000170, Issue 2, January, 1993, Digital Crossconnect System Generic Requirements and Objectives

- ITU-T G.702-1988 Digital hierarchy bit rates
- ITU-T G.703-1991 Physical/electrical characteristics of hierarchical digital interfaces
- ITU-T G.704-1995 Synchronous frame structures used at 1544, 6312, 2048, 8488 and 44736 kbit/s hierarchical levels
- ITU-T G.707-1996 Network node interface for the synchronous digital hierarchy (SDH)
- ITU-T G.823-1993, The control of jitter and wander within digital networks which are based on the 2048 kbit/s digital hierarchy

- IETF RFC1573, Evolution of Interfaces Group of MIB-II, January 1994.
- IETF RFC TBD, Definitions of Managed Objects for the DS3/E3 Interface Type, Date TBD.
- IETF RFC TBD, Definitions of Managed Objects for the DS1, E1, DS2 and E2 Interface Types, Date TBD.

Copyright 2006, Herbert Almus

Seite 74

CES Referenzen (3)

- IETF RFC TBD, Definitions of Managed Objects for the DS0 and DS0 Bundle Interface Types, Date TBD.
- IETF RFC1595, Definitions of Managed Objects for the SONET/SDH Interface Type, March 1994.
- TTC Recommendation JT-G.704, Synchronous Frame Structures Used at Primary and Secondary Hierarchical Levels.
- TTC Recommendation JT-G.703a, Secondary Rate User-Network Interface of Leased Line - Layer 1 Specification.
- ISO/IEC 11573 (1994), Synchronization methods and technical requirements for Private Integrated Services Networks.

ATM Standards and recommendations

- The following organizations are working in the field of ATM standardization
- ITU-TS
 - ◆ (formerly CCITT), focus on international standards
- ETSI
 - ◆ (European Telecommunication Standardization Institute) development of European standards
- Specifications are developed by:
- ATM Forum
 - ◆ vendor driven organization with different technical groups
 - ◆ groups are established only on demand
- IETF -> RFC's
 - ◆ one of the task forces of the Internet Activities Board
 - ◆ small group of core participants
 - ◆ document result: RFC
 - ◆ interim reports in IETF Proceedings
- ITU-TS
 - The ATM related standards are in the following series:
 - ◆ E - General provisions concerning Administrations, users, accounts
 - ◆ G - International telephone connections and international telephone circuits
 - ◆ I - ISDN - General structure - Terminology
 - ◆ M - Principles of maintenance and maintenance organization
 - ◆ Q - Signaling in international services

ITU ATM related recommendations

- E.164 - addressing
- G.702 - Digital Hierarchy Bit Rates
- G.703 - Physical/electrical Characteristics of Hierarchical Digital Interfaces
- G.704 - Synchronous Frame Structure used at Primary and Secondary Hierarchical Levels
- G.706 - Frame Alignment and Cyclic Redundancy Check (CRC) Procedures relating to Basic Frame Structures defined in Recommendation G.704
- G.707 - Synchronous Digital Hierarchy Bit Rates
- G.708 - Network-Node Interface for the Synchronous Digital Hierarchy
- G.709 - Synchronous Multiplexing Structure
- I.113 - Vocabulary of Terms for Broadband Aspects of ISDN
- I.121 - Broadband Aspects of ISDN
- I.142 - B-ISDN Meta-Signaling
- I.150 - B-ISDN ATM Functional Characteristics
- I.211 - B-ISDN Service Aspects
- I.311 - B-ISDN General Network Aspects
- I.321 - B-ISDN Protocol Reference Model and its Application
- I.327 - B-ISDN Network Functional Architecture
- I.350 - Quality of Service (QoS) for Bearer Service and Tele Service
- I.356 - B-ISDN ATM Layer Cell Transfer Performance
- I.361 - B-ISDN ATM Layer Specification
- I.362 - B-ISDN ATM Adaptation Layer (AAL) Functional Description
- I.363 - B-ISDN ATM Adaptation Layer (AAL) Specification
- I.364 - Support of broadband connectionless data service on B-ISDN
- I.371 - Traffic and Congestion control in B-ISDN
- I.413 - B-ISDN User-Network Interface
- I.414 - Overview of Recommendations on layer 1 for ISDN and B-ISDN customer accesses
- I.430 - Layer 1 Specification at the Basic Rate
- I.431 - Layer 1 Specification at the Primary Rate User-Network Interface
- I.432 - B-ISDN User-Network Interface Physical Layer Specification
- I.441 - ISDN User-Network Interface Data Link Layer Specification

Copyright 2006, Herbert Almus

Seite 77

ITU ATM related recommendations

- I.600 - Application of Maintenance Principles to ISDN Subscriber Access and Subscriber Installation
- I.610 - OAM Principles of B-ISDN Access
- M.20 - Maintenance Philosophy for Telecommunications Network
- M.30 - Principles for a Telecommunication Management Network
- M.36 - Principles for the Maintenance of ISDNs
- Q.2010 - General Introduction to Signaling in B-ISDN
- Q.2100 - B-ISDN Signaling AAL, overview
- Q.2110 - AAL, SSCOP
- Q.2120 - Meta-Signaling Protocol
- Q.2130 - SSCF at UNI
- Q.2140 - SSCF at NNI
- Q.2931 - Signaling in B-ISDN

Copyright 2006, Herbert Almus

Seite 78

ETSI ATM related recommendations

- European standards developed by ETSI:
 - User Network Interface
 - ◆ pr ETS 300 299
 - ◆ pr ETS 300 300
 - ATM Layer
 - ◆ pr ETS 300 298-1
 - ◆ pr ETS 300 298-2
 - Resource Management / Traffic Control
 - ◆ pr ETS 300 301
 - ATM Adaptation Layer
 - ◆ DE / NA - 52617 (AAL 1)
 - ◆ DE / NA - 52618 (AAL 3/4)
 - ◆ DE / NA - 52619 (AAL 5)
 - ◆ DE / NA - 52620
 - Operating and Maintenance
 - ◆ DE / NA - 52209
 - ◆ DTR / NA - 52204
 - ◆ DE / NA - 52806
- User Network Interface Signaling
 - ◆ DE / SPS - 5024 (Basic Calls)
 - ◆ DE / SPS - 5034 (Supplementary service)
- Signaling AAL
 - ◆ DE / SPS - 5026 -1
 - ◆ DE / SPS - 5026 -2
- Address ETSI:
 - ETSI Secretariat
 - 06921 Sophia Antipolis
 - Route des Lucioles, Vallebonne
 - Tel.: +33.92944200
 - Fax: +33.93654716

Copyright 2006, Herbert Almus

Seite 79

ATM Forum

- Goal:
 - Acceleration of ATM products and services deployment through rapid convergence on interoperability specifications and promotion of industry cooperation.
- Characterization:
 - ◆ world-wide non-profit organization
 - ◆ vendor driven, founded by Northern Telecom, US Sprint, Cisco and Adaptive Corp. in 1991
 - ◆ more than 800 members (spring 1997)
- principal members
 - ◆ get all information, are expected to contribute full time people
 - ◆ pay \$10.000 per year
- auditing members / user members
 - ◆ get a lot of information (especially all draft specifications), can attend plenary or general meetings
 - ◆ pay \$1.500 per year
- Approved ATM-Forum Specifications
 - WWW-Page to order or download the above specifications:
 - http://www.atmforum.com/atmforum/spec_order.html
- Technical Working Groups
 - ◆ Physical Layer
 - ◆ Signaling
 - ◆ Private NNI
 - ◆ Network Management
 - ◆ Traffic Management
 - ◆ B-ICI
 - ◆ Service Aspects and Applications
 - ◆ LAN Emulation
 - ◆ Testing
 - ◆ Multiprotocol
 - ◆ Residential Broadband
 - ◆ ...
- Groups are established only on demand!

Copyright 2006, Herbert Almus

Seite 80

RFCs

- In the area of ATM networking different Requests for Comment (RFC's) were developed and presented within the framework of the internet engineering task force (IETF):
- RFC 1483 - Multiprotocol Encapsulation over ATM Adaptation Layer 5.
- RFC 1754 - IP over ATM Working Group's Recommendations for the ATM Forum's Multiprotocol BOF. Version 1. January 1995
- RFC 1577 - Classical IP and ARP over ATM.
- RFC1755 - UNI Signaling Support for IP over ATM
- RFC 1626 - Default IP MTU for use over ATM AAL5.
- RFC 1680 - IPng Support for ATM Services.
- RFC 1695 - Definitions of Managed Objects for ATM Management Version 8.0 using SMI v2.
- RFC 1821 - Integration of realtime services in IP ATM
- RFC 1932 - IP over ATM: A Framework Document

Copyright 2006, Herbert Almus

Seite 81

Abkürzungen

- | | |
|--|--|
| <ul style="list-style-type: none"> ■ AA - administrative authority ■ AAE - abgesetzte ATM Einheit ■ AAL - ATM adaptation layer ■ ABR - Available Bitrate ■ ADM - add/drop multiplexer ■ AFI - authority and format identifier ■ AIS - alarm indication signal (SDH) ■ AL - alignment ■ AMS - audiovisual multimedia services ■ ANP - AAL2 negotiation procedure (AAL2) ■ ANSI - american national standard institute ■ APS - automatic protecting switching ■ ARP - address resolution protocol ■ ASC - american standards committee ■ ASN.1 - abstract syntax notation one ■ ATDM - asynchronous time division multiplexing ■ ATE - ATM terminating equipment ■ ATM - asynchronous transfer mode ■ ATMR - ATM Ring ■ ATV - advanced television ■ AU - administrative unit OR access unit | <ul style="list-style-type: none"> ■ BALI - Berlin ATM LAN Interconnection ■ BAsize buffer allocation size ■ BCD - binary coded digit ■ BCOB - Broadband Connection Oriented BearerB-ICI - Broadband Intercarrier Interface ■ B-ISDN - broadband integrated services digital network ■ B-ISUP broadband ISDN user part ■ BE - beginning-end-tag ■ BECN - backward explicit congestion notification ■ Bellcore - Bell Communication Research ■ BER - bit error rate ■ B-ET - exchange termination for B-ISDN ■ BGREJ - begin reject ■ BIP - bit interleave parity ■ B-ISDN - broadband integrated service digital network ■ B-LT - line termination for B-ISDN ■ B-NT1 - network termination equipment type 1 for B-ISDN ■ B-NT2 - network termination equipment type 2 for B-ISDN |
|--|--|

Copyright 2006, Herbert Almus

Seite 82

Abkürzungen

- BOC - Bell operating company
- BOM - begin of message
- bps - bits per second
- BRI - basic rate interface
- BT - burst tolerance
- Btag - begin tag
- B-TA - terminal adapter for B-ISDN
- B-TE1 - terminal equipment type 1 for B-ISDN
- B-TE2 - terminal equipment type 2 for B-ISDN
- BUS - broadcast and unknown server

- CAC - connection admission control
- CBDS - connectionless broadband data service
- CBOS - connectionless broadband data service
- CBR - constant bit rate
- CC - connection control timer
- CCITT - Comité Consultatif International Téléphonique et Telegraphique
- CCR - Current Cell Rate
- CDV - cell delay variation
- CDVT - CDV tolerance
- CEO - customer equipment

- CEPT - conference of european postal & telecommunication administration
- CER - cell error ratio
- CIR - committed information rate
- CL - connectionless (service)
- CLDS - connectionless data service
- CLNAP - connectionless network access protocol
- CLNIP - connectionless network interface protocol
- CLNP - connectionless network protocol
- CLNS - connectionless network service
- CLP - cell loss priority
- CLR - cell loss ratio
- CLS - connectionless server
- CLSF - connectionless service-function
- CMI - coded mark inversion
- CMIP - common management information protocol
- CMIS - common management information service
- CMISE - CMIS element
- CMR - cell misinsertion rate
- CN - customer network
- CNM - customer network management

Copyright 2006, Herbert Almus

Seite 83

Abkürzungen

- CO - connection oriented (service) OR central office
- COM - continuation of message
- CONS - connection oriented network services
- CPCS - common part convergence sublayer (AAL)
- CPE - customer premises equipment
- CPI - common part identifier
- CPS - Common Part Sublayer (AAL2)
- CPS-PP - CPS packet payload (AAL2)
- CRC - cyclic redundancy check
- CRF(VC) - virtual channel connection related functions
- CRF(VP) - virtual path connection related functions
- CS - convergence sublayer
- CSA - canadian standards association
- CSI - CS Indication
- CSU - channel service unit
- CSMA/CD - carrier sense multiple access with collision detection
- CVs - coding violatons

- DA - destination address
- DACS - digital access and cross-connect system
- dB - decibel
- dBm - decibel (referencing 1 mW)
- DFI - domain specific part format identifier
- DCC - data communication channel
- DCC - data country code
- DCE - data circuit terminating equipment
- DCS - digital cross-connect system
- DE - discard eligible
- DLCI - data link connection identifier
- DNA - digital network architecture
- DoD - department of defense
- DQDB - distributed queue dual bus
- DSP - digital signal processor
- DSS - distributed sample scrambler
- DSU - data service unit OR digital switching unit
- DSX - digital signal cross-connect
- DS-x - digital signal x (i.e. x=3, DS-3)
- DTE - data terminal equipment
- DTMF - dual tone multifrequency
- DXC - digital cross-connect
- DXI - data exchange interface

Copyright 2006, Herbert Almus

Seite 84

Abkürzungen

- EA - extended address
- ECSA - exchange carriers standards association
- EDFG - Edge Device Functional Group
- EFCI - explicit forward congestion indication
- EFI - errored frame indicator (DS3)
- EMA - enterprise management architecture
- END - end
- ENDAK - end acknowledgment
- EOC - embedded operations channel
- EOM - end of message
- ES - errored seconds
- ESI - end system identifier
- ET - exchange termination
- Etag - end tag (AAL3/4)
- ETSI - european telecommunications standards institute
- FCS - frame check sequence
- FC - forward congestion indicator
- FDDI - fiber distributed data interface
- FDM - frequency division multiplexing
- FEBE - far end block error (PDH)
- FEC - forward error correction
- FECN - forward explicit congestion notification
- FERF - far end receive failure (SDH)
- FFOL - FDDI follow-on-LAN
- FG - Functional Group
- FIFO - first in first out
- FOT - fiber optic terminal
- fps - frames per second
- FR - frame relay
- FRM - fast resource management
- FTAM - file transfer access and management
- FTP - file transfer protocol
- FTTC - fiber to the curb
- FTTH - fiber to the home
- GCRA - generic cell rate algorithm
- GFC - generic flow control
- GPS - Navstar global positioning satellite
- GSM - global system for mobile communications
- GW - gateway

Copyright 2006, Herbert Almus

Seite 85

Abkürzungen

- HBFG - Host Behavior Functional Group
- HEC -header error control
- HDLC - high-level data link control
- HDTV - high definition television
- HIPPI - high performance parallel interface
- HSC - header check sequence
- HSLAN - high speed LAN
- HSSI - high speed service interface
- Hz - Hertz (cycles per second)
- IAB - internet activity board
- ASG - Internetwork Address Sub-Group
- IASGid - Internetwork Address Sub-Group Identifier
- IBSG - Internetwork Broadcast Sub-Group
- IBUFG - Internetwork Broadcast/Unknown Functional Group
- ICD - international code designator
- ICFG - IASG Coordination Function Group
- ICI - interexchange carrier interface
- ICMP - internet control message protocol
- IDLC - integrated digital loop carrier
- IDMR - inter domain multicast routing
- IDU - interface data unit
- IE - information element
- IEEE - institute of electrical and electronic engineers
- IETF - internet engineering task force
- IISP - interim interswitch Signaling protocol
- ILMI - integrated local management interface
- IN - intelligent network
- InARP - inverse address resolution protocol
- IP - internet protocol
- I-PNNI - integrated private network-network interface
- IPX - internetwork packet exchange
- ISDN - integrated services digital network
- ISO - international standards organization
- ISSI - inter-switching system interface
- ISUP - ISDN user part
- ITU - international telecommunication union
- ITU-TS - telecommunication standardisation sector of ITU
- IUT - implementation under test
- IWU - interworking unit

Copyright 2006, Herbert Almus

Seite 86

Abkürzungen

- JPEG - joint photographic experts group
- LAN - local area network
- LANE - LAN Emulation
- LAP-B - link access procedure balanced (X.25)
- LAP-D - link access procedure D (ISDN)
- LAP-F - link access procedure F
- LATA - local access and transport area
- LBA - leaky bucket algorithm
- LE - layer entity
- LEC - LANE client (LANE)
- LEC - local exchange carrier
- LECS - LANE configuration server
- LEN - local exchange node
- LES - LANE server (LANE)
- LGN - logical group node
- LI - length indication
- LIS - logical IP subnet (Classical IP)
- LLC - logical link control
- LL-ID - loopback location identification
- LME - layer management entity
- LMI - local management interface
- LOCS - loss of cell synchronization (SDH)
- LOF - loss of framing (SDH)
- LOH - Line overhead
- LOP - loss of pointer (SDH)
- LOPS - loss of PRBS synchronization (SDH)
- LOS - loss of signal
- LSB - least significant bit
- LSCR - loss of scrambler synchronization (SDH)
- LT - line termination
- LTE - line terminating equipment (SDH)
- LUNI - LANE UNI
- MAC - media access control
- MAN - metropolitan area network
- MARS - multicast address resolution server
- MAU - media access unit
- MBS - maximum burst size
- MCR - Minimum Cell Rate
- MIB - management information base
- MID - multiplexing identifier (ATM) OR message identifier (DQDB)
- MIS - management information system

Copyright 2006, Herbert Almus

Seite 87

Abkürzungen

- MMF - multi mode fiber
- MPDU - management protocol data unit
- MPEG - motion picture experts group
- MPOA - Multiprotocol over ATM
- MS - multiplexer section
- MSB - most significant bit
- MSOH - multiplexer section overhead
- MSVC - meta-Signaling virtual channel
- MT - message type
- MTP - message transfer part
- MTU - maximum transmission unit
- MUX - multiplexer
- NRZ - non-return-to-zero code
- NSAP - network service access point
- NT - network termination
- NTSC - national television standards committee
- OAM - operation and maintenance
- OCD - out of cell delineation
- OC-x - optical carrier level x
- ODI - open data interface
- OH - overhead
- OOF - out of frame
- OS - operating system
- OSI - open system interconnection
- OSPF - open shortest path first
- OTDR - optical time domain reflector
- OUI - organizationally unique identifier
- NCP - network control point
- NDIS - network device interface specification
- NE - network element
- NFS - SUN network file system
- NI - network interconnect
- N-ISDN - narrowband ISDN
- NMS Network Management System
- NNI - network-network-interface
- NPC - network parameter control
- PABX - private automatic branch exchange
- PAD - packet assembler/disassembler
- PBX - private branch exchange
- PC - protocol control
- PCM - puls code modulation

Copyright 2006, Herbert Almus

Seite 88

Abkürzungen

- PCN - personal communications network
- PCO - point of control and observation
- PCR - peak cell rate
- PDH - plesichronous digital hierachy
- PDN - public data network
- PDU - protocol data unit
- PG - peer group
- PGL - peer group leader
- PHY - physical layer
- PICS - protocol impelmentation conformance statements
- PID - protocol identification
- PIXIT protocol implementation eXtra information for testing
- PLCP - physical layer convergence protocol
- PM - physical medium
- PMD- physical medium dependent
- PNNI - private network-network interface
- POH - path overhead
- PRI - primary rate interface
- PRN - pseudo random noise
- PSPDN - packet switched public data network
- PSTN - public switched telephone network
- PT - payload type
- PTE - path terminating equipment (SDH)
- PTSE - PNNI topology state element (PNNI)
- PTSP - PNNI topology state packet (PNNI)
- PTT - postal, telegraph & telephone
- PTI - payload type indicator
- PVC - permanent virtual channel
- PVCC - permanent virtual channel connection
- PVPC - permanent virtual path connection
- QoS - quality of service
- RARP - reverse address resolution protocol
- RBOC - regional Bell operating company
- RD - routing domain
- RDI - remote defect indicator (SDH)
- RFC - request for comments
- RIP - routing information protocol
- RM - Resource Management
- ROLC - routing over large clouds
- RPC - remote procedure call

Copyright 2006, Herbert Almus

Seite 89

Abkürzungen

- RSOH - regenerator section overhead (SDH)
- RSFG - Route Server Functional Group
- RT - router
- RTS - residual time stamp (AAL1)
- SA - source address
- SAAL - Signaling ATM adaptation layer (AAL)
- SAP - service access point
- SAPI - service access point identifier
- SAR - segmentation and reassembly sublayer (AAL)
- SC - sequence count (AAL)
- SCR - sustainable cell rate
- SDH - synchronous digital hierachy
- SDLC - synchronous data link control
- SDU - service data unit
- SEAL - simple and efficient AAL
- SECB - severely errored cell block ratio
- SEL - selector
- SES - severely errored seconds
- SIP - SMDS interface protocol
- SIR - sustained information rate
- SLC - subscriber loop carrier
- SMDS - switched multimegabit data service
- SMF - single mode fiber
- SN - sequence number
- SNA - system network architecture
- SNAP - subnetwork access protocol
- SNDCF - Sub-Network Dependent Convergence Function
- SNI - subscriber network interface
- SNMP - simple network management protocol
- SNP - sequence number protection
- SOH - section overhead
- SONET - synchronous optical network
- SPE - synchronous payload envelope
- SPF - shortest path first protocol
- SR - source routing
- SRTS - synchronous residual time stamp (AAL1)
- SSAP - source service access point
- SS - SMDS switching system
- SSCF - service specific coordination function
- SSCOP - service specific connection oriented protocol (SAAL)

Copyright 2006, Herbert Almus

Seite 90

Abkürzungen

- SSCS - service specific convergence sublayer (AAL)
- SSS - self synchronizing sample scrambler
- SS7 - Signaling system number 7
- STDm - synchronous time division multiplexing
- STE - section terminating equipment
- STF - start field (AAL2)
- STM - synchronous transfer mode
- STM-x - synchronous transport module level x (i.e. x=1, STM-1)
- STP - shielded twisted pair OR spanning tree protocol
- STS-x - synchronous transport signal level x (i.e. x=3, STS-3)
- STS-xC - STS-x concatenated (i.e. x=3, STS-3C)
- SUT - system under test
- SVC - Signaling virtual channel
- TA - terminal adapter
- TAT - theoretical arrival time
- TC - transmission convergence sublayer (Physical Layer)
- TCP - transmission control protocol
- TDM - time division multiplexing
- TE - terminal equipment
- TM - traffic management
- TP4 - transport protocol class 4
- TTCN - tree and tabular combined notation
- TU - tributary unit
- TUG - tributary unit group
- UBR - Unspecified bitrate
- UDP - user datagram protocol
- UME - UNI Management Entity
- UNI - user-network-interface
- UPC - usage parameter control
- UPT - universal personal telecommunications
- UTP - unshielded twisted pair
- UU - user-to-user indication
- VBR - variable bit rate
- VC - virtual channel
- VC-n - virtual container n
- VCC - virtual channel connection
- VCI - virtual channel identifier

Copyright 2006, Herbert Almus

Seite 91

Abkürzungen

- VLAN - virtual LAN
- VP - virtual path
- VPC - virtual path connection
- VPCI - VPC identifier
- VPI - virtual path identifier
- VPN - virtual private network
- VSA - virtual scheduling algorithm
- VT - virtual tributary
- VTG - virtual tributary group
- VTOH - virtual tributary overhead
- WAN - wide area network
- XTP - express transfer protocol

Copyright 2006, Herbert Almus

Seite 92

ATM – Literatur (engl.)

- **ATM solutions for enterprise internetworking**
 - ◆ David Ginsberg
 - ◆ Verlag: Addison Wesley
 - ◆ ISBN 0-201-87701-5

- **ATM Resource Library Volumes I-III**
 - ◆ Prentice Hall Series in Advanced Communications Technologies
 - ◆ ISBN 0-13-793779-2

- **Planning & Managing ATM Networks**
 - ◆ Verfasser: Daniel Minoli, Thomas Golway
 - ◆ Verlag: Manning Publications Co. Greenwich
 - ◆ ISBN 0-13-262189-4